



 turvec

 PUMP
□ AUTO □ PRESTA □ DUNLOP

TYRE WIDTH	RECOMMENDED PRESSURE	
20 MM	9,0 BAR	130 PSI
23 MM	8,0 BAR	115 PSI
24 MM	7,0 BAR	100 PSI
28 MM	6,0 BAR	85 PSI
30 MM	5,5 BAR	80 PSI
32 MM	5,0 BAR	70 PSI
35 MM	4,5 BAR	65 PSI
37 MM	4,5 BAR	65 PSI
40 MM	4,0 BAR	58 PSI
42 MM	4,0 BAR	58 PSI
44 MM	3,5 BAR	50 PSI
47 MM	3,5 BAR	50 PSI
50 MM	3,0 BAR	45 PSI
54 MM	2,5 BAR	35 PSI
57 MM	2,2 BAR	32 PSI
	2,0 BAR	30 PSI

Public Bike Pumps help keep cyclists moving and work to encourage active travel.

Offering a highly durable design, every pump can be custom branded and painted to any standard RAL colour.



REGISTERED
TU/PO no. 1366587

3D view

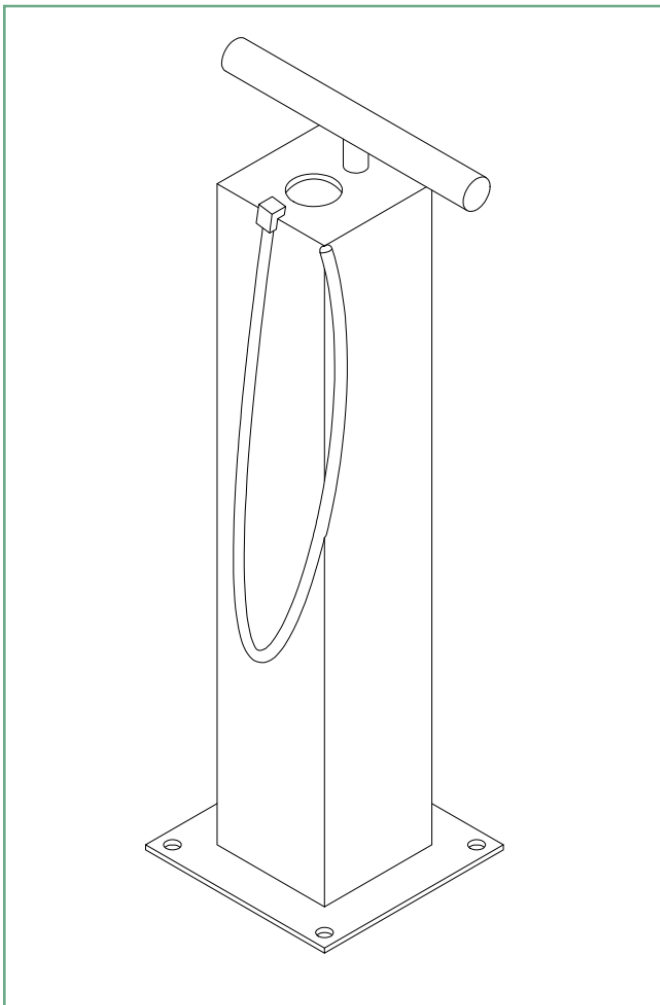

Front elevation

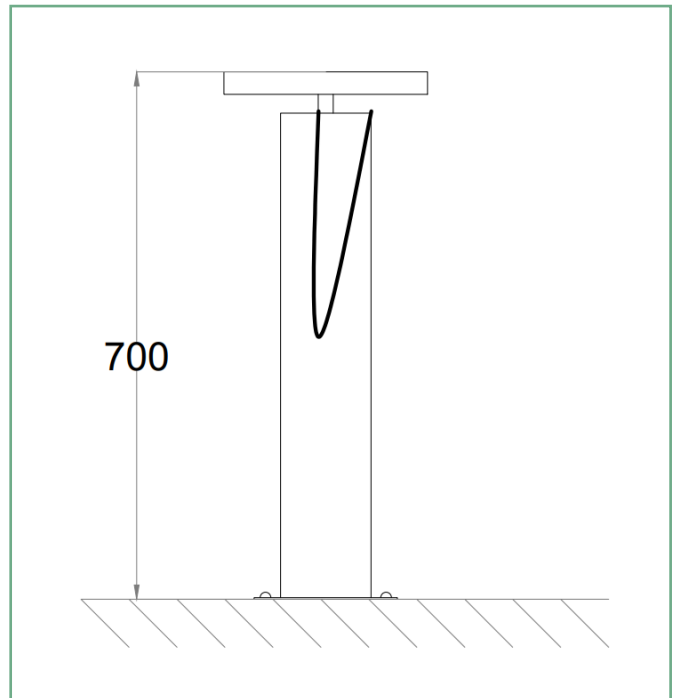

Standard RAL Colours

RAL 1021	RAL 2008	RAL 3020
RAL 4004	RAL 4010	RAL 5002
RAL 5003	RAL 5012	RAL 5015
RAL 5017	RAL 6005	RAL 6018
RAL 7001	RAL 7016	RAL 7035
RAL 9005	RAL 9006	RAL 9010

Product details

Product name	Public Bike Pump
Product code	VEC112
Fixing	Surface mounted
Standard finish	Galvanised steel, powder coated to any standard RAL colour, with branding
Optional finish	Bespoke RAL colour
Branding	Incorporate any company or council logo
Pressure	10 bar
Valve	Presta and Schrader
Weight	~15kg
Dimensions	700 x 200 x 200 mm
Installation	All units delivered pre-assembled and ready to install



Project: Windmill Green
Sector: Commercial
Year completed: 2020



Project: St. Georges Fields
Sector: Residential
Year completed: 2021



Project: County Mayo
Sector: Public
Year completed: 2021